

A series Mini Walkie Pallet Truck / Li-Ion specification

Distinguishing mark	HANGCHA GROUP CO.,LTD.			
	1.1	Manufacturer		CBD12-AMC1-I
1.2	Manufacturer's type designation		Pedestrian	
1.4	Operator type: hand, pedestrian, standing, seated, order-picker			
1.5	Rated capacity/rated load	Q (kg)	1200	
1.6	Load centre distance	c (mm)	600	
1.8	Load distance, centre of drive axle to fork	x (mm)	950	
1.9	Wheelbase	y (mm)	1165 ¹⁾	
Weight	2.1	Service Weight(Including battery)	kg	130
		Battery weight	kg	4.8
Tyres, chassis	3.1	Tyres: solid rubber, superelastic, pneumatic, polyurethane		PU
	3.2	Tyre size, front		Φ210x70
	3.3	Tyre size, rear		Φ75x65
	3.4	Additional wheel (dimensions)		/
	3.5	Wheels, number front / rear (x = driven wheels)		1x/4
	3.6	Tread, front	b ₁₀ (mm)	/
3.7	Tread, rear	b ₁₁ (mm)	410	
Dimensions	4.4	Lift	h ₃ (mm)	115
	4.15	Fork height,lowered	h ₁₃ (mm)	75
	4.19	Overall length	l ₁ (mm)	1580
	4.21	Overall width	b ₁ (mm)	560
	4.22	Fork dimensions	s/e/l (mm)	53/150/1150
	4.25	Distance between fork-arms	b ₅ (mm)	560
	4.32	Ground clearance, centre of wheelbase	m ₂ (mm)	22
	4.35	Turning radius	W _a (mm)	1330 ¹⁾
	4.36	Aisle width for pallets 1000 x 1200 crossways	A _{st} (mm)	1785 ^{1) 2)}
	4.37	Aisle width for pallets 800 x 1200 lengthways	A _{st} (mm)	1835 ^{1) 3)}
Performance data	5.1	Travel speed,laden/unladen	km/h	4/4,5
	5.2	Lift speed,laden/unladen	m/s	0.015/0.023
	5.3	Lowering speed,laden/unladen	m/s	0.064/0.021
	5.8	Max Gradeability,laden/unladen	%	4/10
Electric engine	6.1	Drive motor rating S2 60 min	kW	0.65
	6.2	Lift motor rating at S3 15%	kW	0.36
	6.4	Battery voltage,rated capacity	V/Ah	24/20
	8.1	Type of drive control		DC
	9.1	Manufacturer		Curtis

Note: 1) When fork lowered,+55mm; 2)According to the VDI2198 standard,+350mm; 3)According to the VDI2198 standard,+195mm.

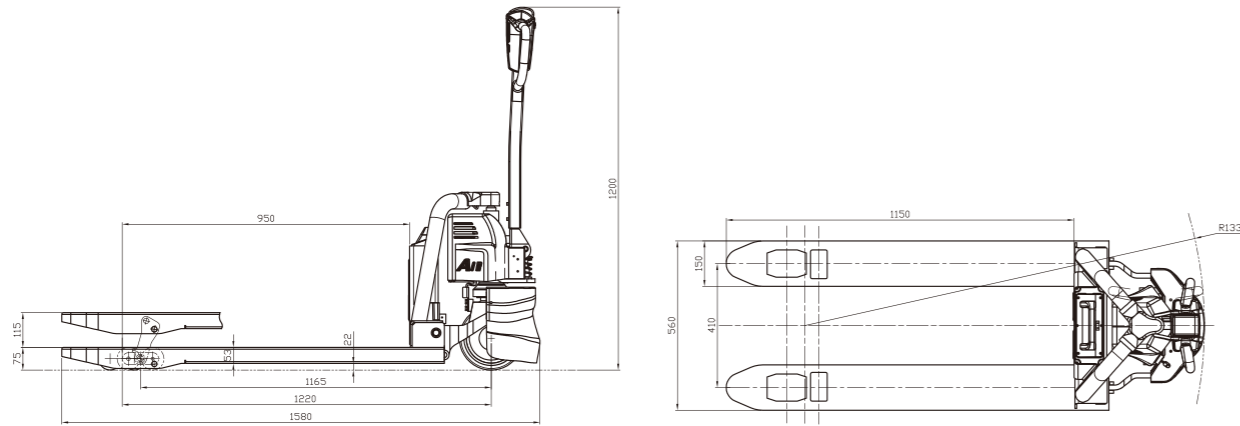

ZHEJIANG HANGCHA IMP. & EXP. CO., LTD.

Factory site: 666 Xiangfu Road,
Hangzhou, Zhejiang, China (311305)

Tel: +86-571-88926735 88926755
Fax: +86-571-88926789 88132890

sales@hcforklift.com
www.hcforklift.com



Follow us on
Facebook



Follow us on
YouTube



Follow us on
WeChat



ISO14001
ISO14001:2015



ISO9001
ISO9001:2015



HANGCHA trucks conform
to the European Safety
Requirements.

2018 VERSION 1/COPYRIGHT 2018/03

HANGCHA GROUP CO., LTD. reserves the right to make any changes without notice concerning colors,equipment,or specifications detailed in this brochure, or to discontinue individual models. The colors of trucks, delivered may differ slightly from those in brochures.

A series Mini Walkie Pallet Truck / Li-Ion

with capacity of 1,200kg

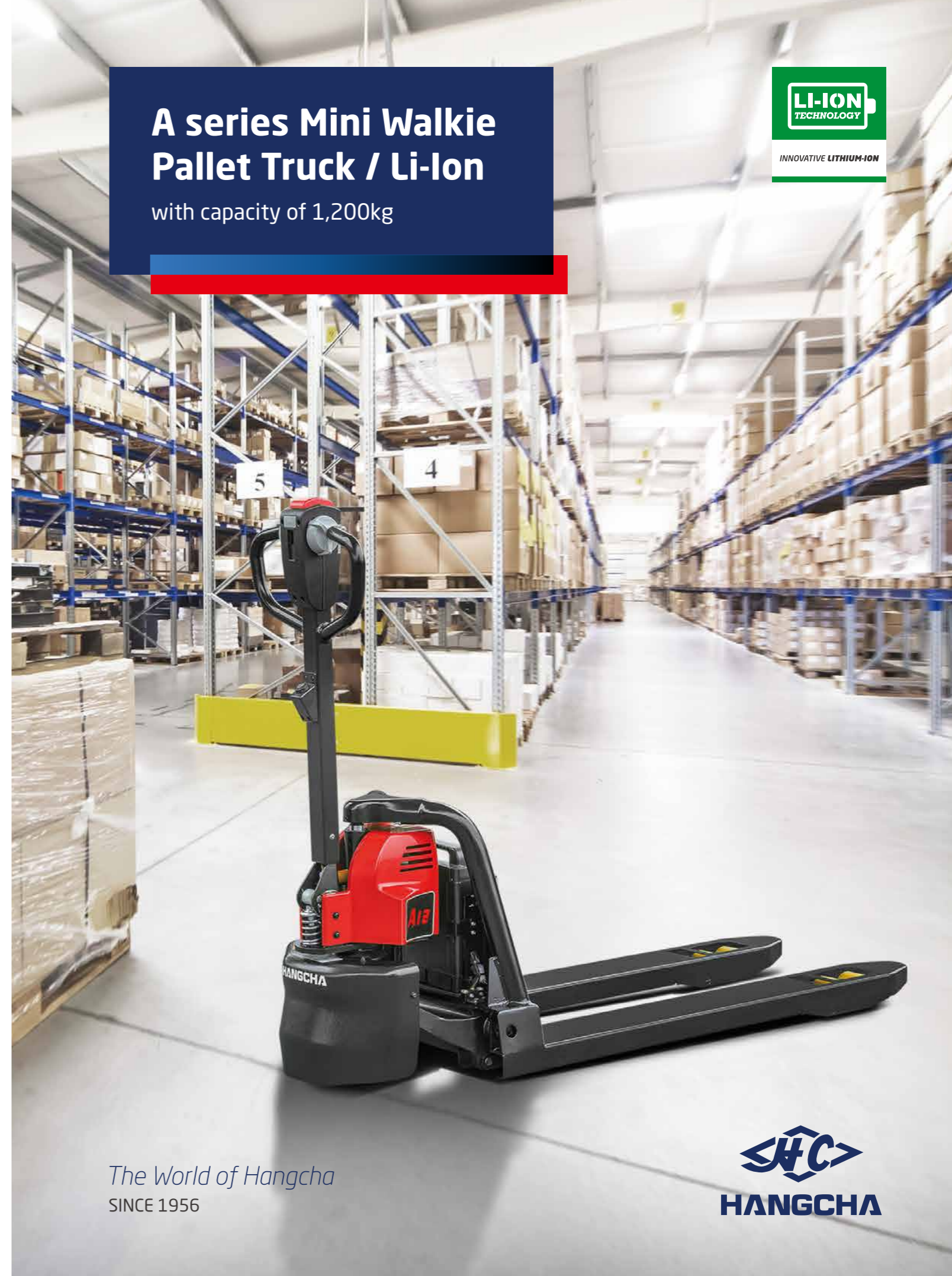

The World of Hangcha
SINCE 1956



THE PALLET TRUCK WITH Li-Ion TECHNOLOGY

A series mini walkie pallet truck / Li-Ion will replace the hand pallet truck perfectly. It can be used in such as retail environment, pharmaceutical factory... especially in narrow aisle.



130kg

Service weight (including battery): 130kg, easy control

High efficient:
Full electric control, travelling, lifting, lowering

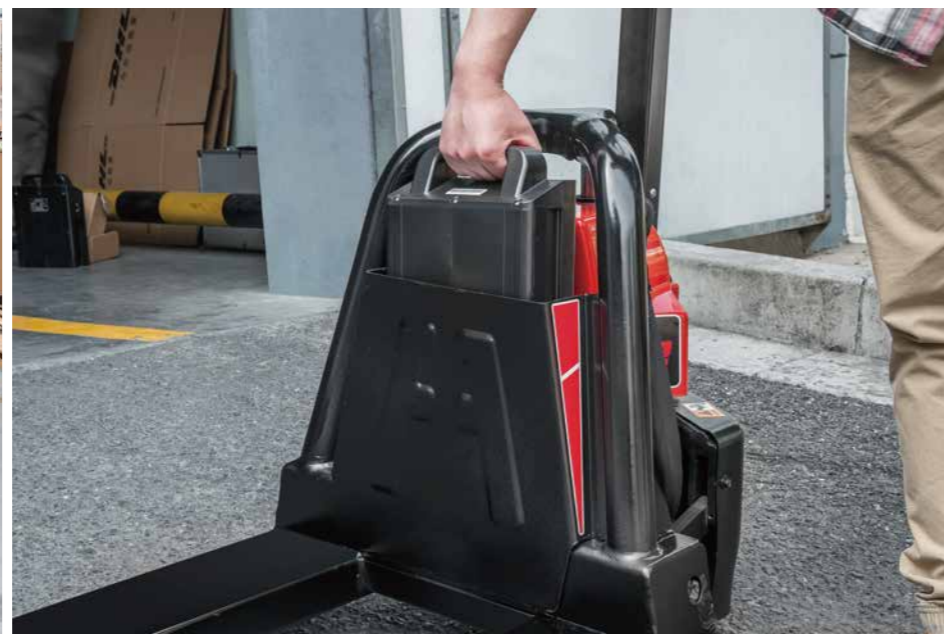

QUICK CHARGING, LONG WORKING TIME;



**1200 CYCLES
3 YEARS WARRANTY
1 YEAR STANDBY LIFE**

Remaining capacity of lithium-ion battery is 70% after 1200 cycles, and warranty period of the battery is 3 years or 6000 hours.

Power loss of the battery is extremely low when the power is OFF, and the standby state can last for a year with no reduction of battery service life.

**100 %
2 hours charge**

3.5 hours working time

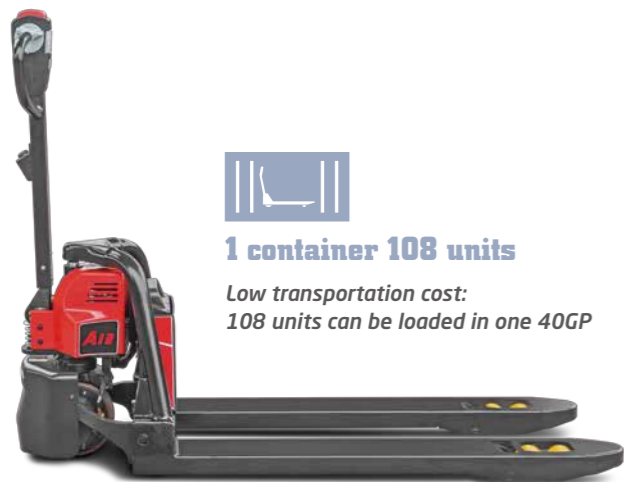

1 container 108 units

Low transportation cost:
108 units can be loaded in one 40GP



1330 mm
Turning radius